

DC Circuits

- Electromotive Force
- Resistor Circuits
 - Connections in parallel and series
- Kirchoff's Rules
 - Complex circuits made easy
- RC Circuits
 - Charging and discharging

Electromotive Force (EMF)

EMF, \mathcal{E} , is the work per unit charge done by a source such as a battery or generator.

Ideally, $\mathcal{E} = \Delta V$

But every real life source has *internal resistance*, r

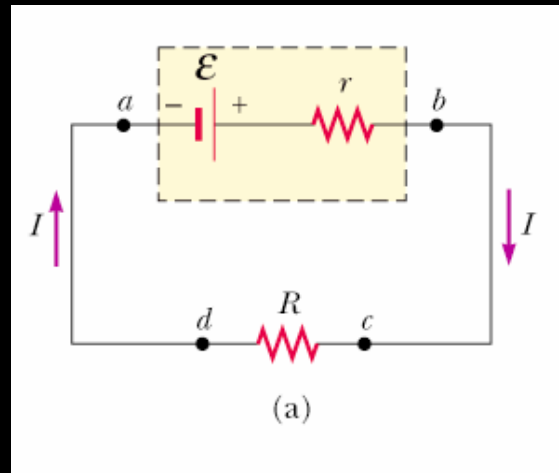
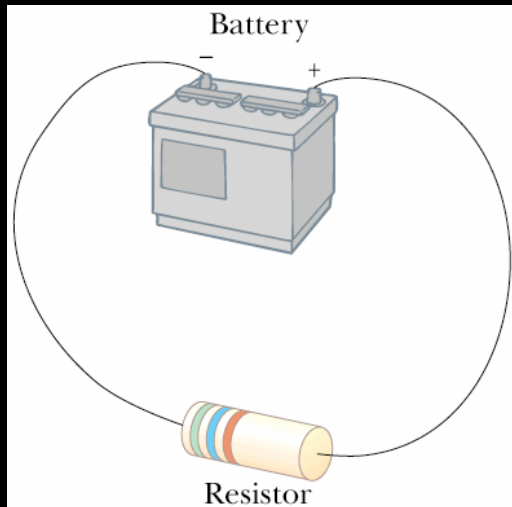

$$\Delta V = V_b - V_a = \mathcal{E} - Ir$$

If $I=0$ then $\Delta V = \mathcal{E}$

$$\mathcal{E} = IR + Ir$$

$$I = \frac{\mathcal{E}}{R + r}$$

$$I\mathcal{E} = I^2 R + I^2 r$$

Resistors in Series

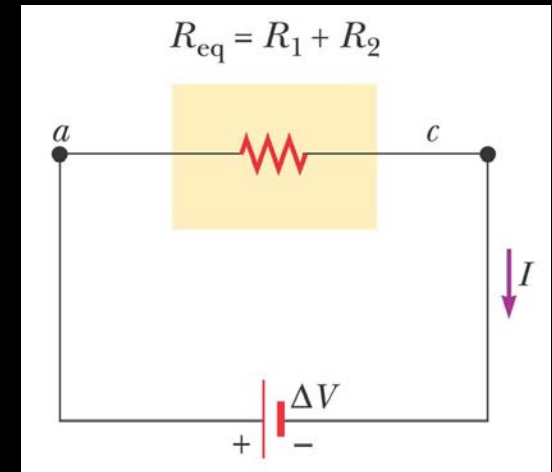
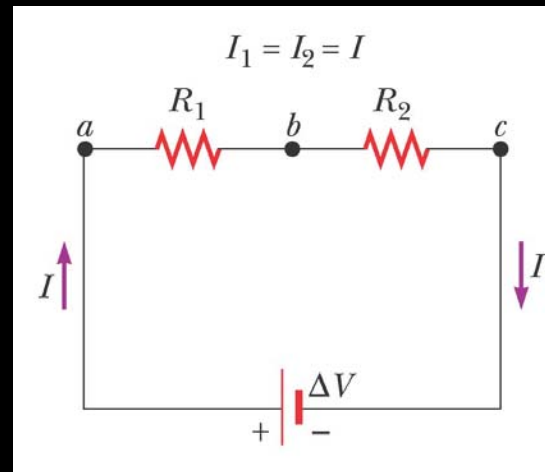
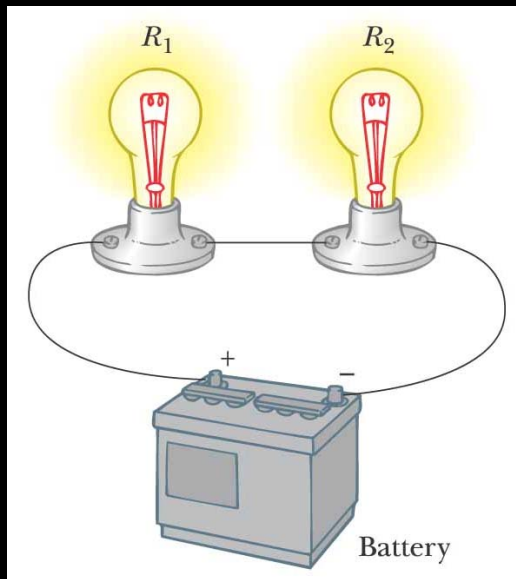

$$\Delta V = IR_1 + IR_2 = I(R_1 + R_2)$$

$$R_{eq} = R_1 + R_2$$

$$R_{eq} = R_1 + R_2 + R_3 + \dots$$

In a series connection, the current through one resistor is the same as the other, the potential drop on each resistor adds up to the applied potential.

Resistors in Parallel

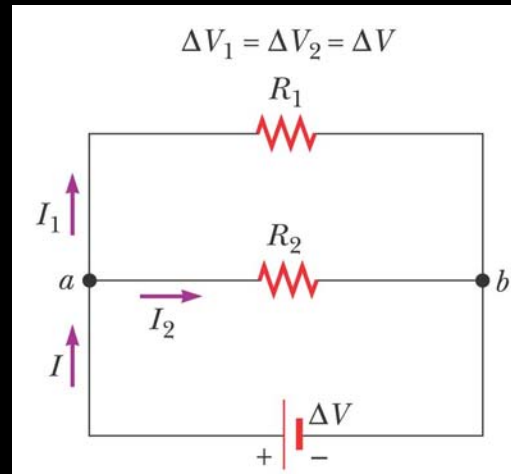
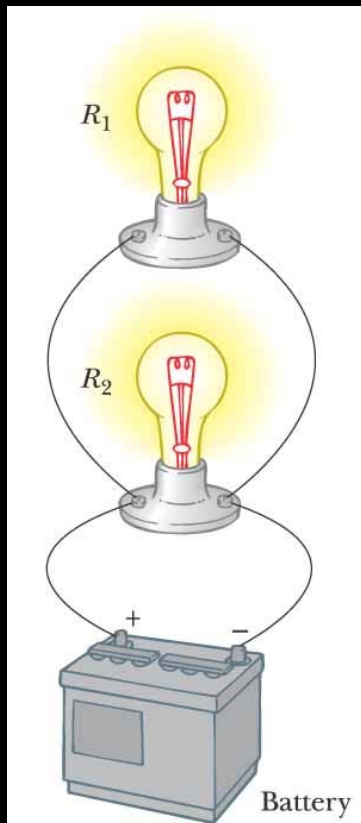

$$I = I_1 + I_2$$

$$I = \frac{\Delta V}{R_1} + \frac{\Delta V}{R_2} = \Delta V \left(\frac{1}{R_1} + \frac{1}{R_2} \right)$$

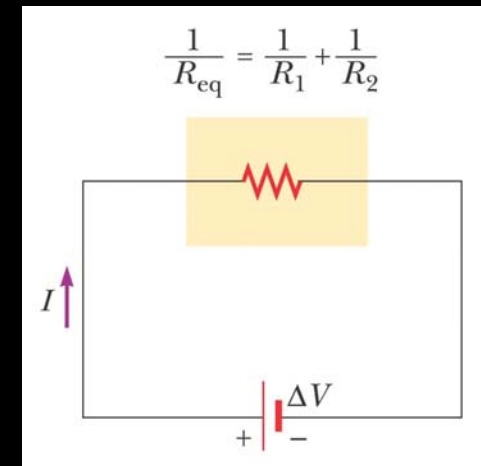

$$\frac{1}{R_{eq}} = \frac{1}{R_1} + \frac{1}{R_2}$$

$$\frac{1}{R_{eq}} = \frac{1}{R_1} + \frac{1}{R_2} + \frac{1}{R_3} + \dots$$

In a parallel connection, the voltage across the resistors are the same, current gets divided at the junctions.

Concept Question

Charge flows through a light bulb. Suppose a wire is connected across the bulb as shown. When the wire is connected,

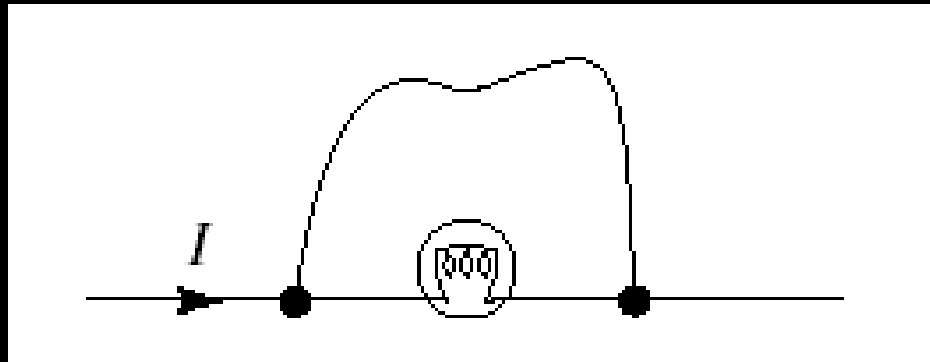

1. all the charge continues to flow through the bulb.
2. half the charge flows through the wire, the other half continues through the bulb.
3. all the charge flows through the wire.
4. none of the above

Concept Question

Two light bulbs A and B are connected in series to a constant voltage source. When a wire is connected across B as shown, bulb A

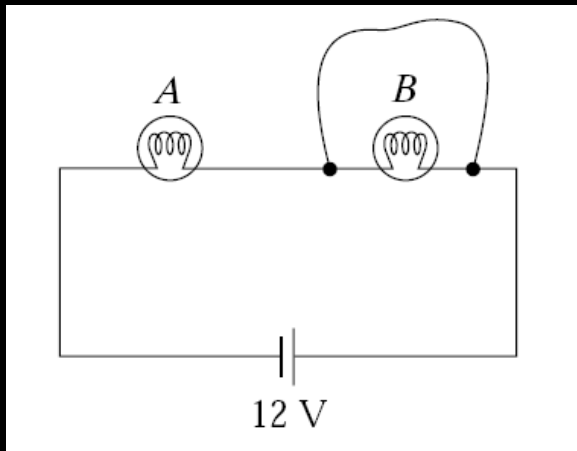

1. burns more brightly.
2. burns as brightly.
3. burns more dimly.
4. goes out.

Problem 28.11

A 6 V battery supplies current to the circuit shown in the figure. When the double-throw switch S is open, as shown in the figure, the current in the battery is 1.00 mA. When the switch is closed in position 1, the current in the battery is 1.10 mA. When the switch is closed in position 2, the current in the battery is 2.10 mA. Find the resistances R_1 , R_2 , and R_3 .

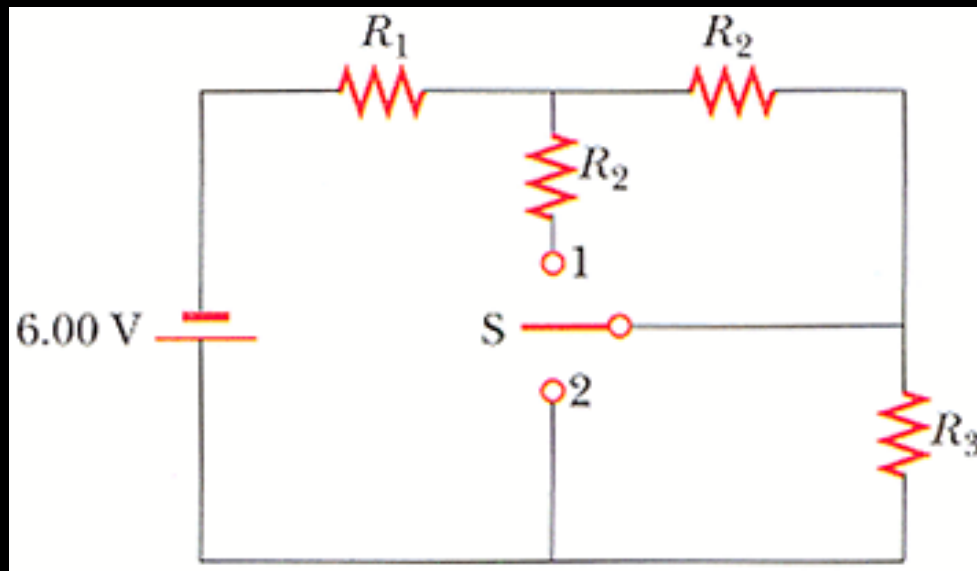

More Complicated Circuits

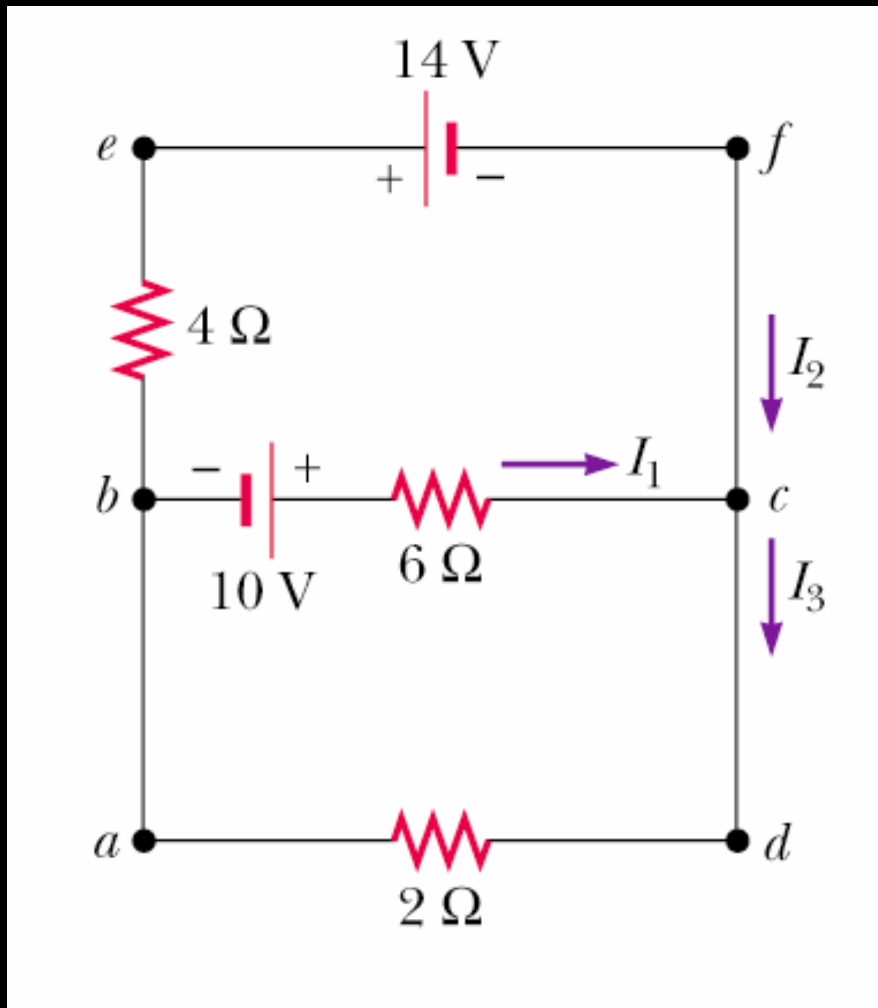

Not really possible to reduce to a single loop with an equivalent resistance

Kirchoff's Rules

- The sum of currents entering a junction is equal to the sum of currents leaving it.
- The sum of potential differences across all elements around a closed loop is zero.

$$\sum_{\text{junction}} I_{in} = \sum_{\text{junction}} I_{out}$$

$$\sum_{\text{closed loop}} \Delta V = 0$$

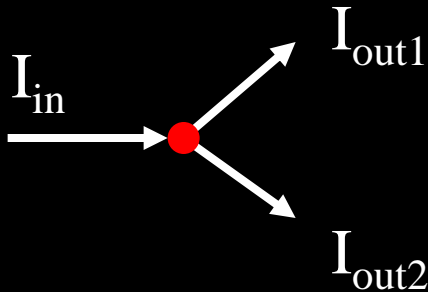

$$\Delta V + \Delta V + \Delta V = 0$$

Sign Conventions

- The potential change across a resistor is $-IR$ if the loop is traversed **along** the chosen direction of current (potential *drops* across a resistor).
- The potential change across a resistor is $+IR$ if the loop is traversed **opposite** the chosen direction of current.
- If an emf source is traversed **in the direction** of the emf, the change in potential is $+\mathcal{E}$.
- If an emf source is traversed **opposite the direction** of the emf, the change in potential is $-\mathcal{E}$.

Using Kirchoff's Rules

Draw a circuit diagram and label all known and unknown quantities.

Assign currents to each branch. Don't worry about direction, but be consistent.

Apply the junction rule to any junction in the circuit that provides a relationship between the various currents.

Apply the loop rule to as many loops in the circuit as necessary to solve for the unknowns. Follow the sign rules.

Solve the equations simultaneously.

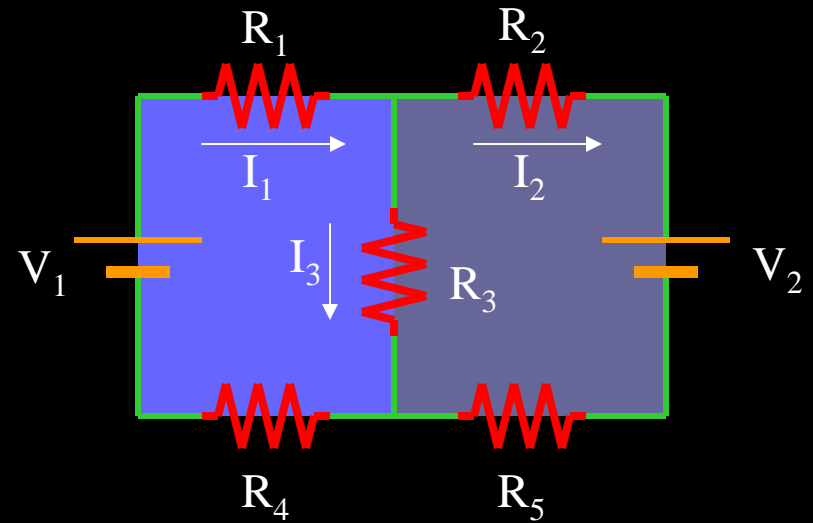

$$I_1 - I_2 - I_3 = 0$$

$$V_1 - I_1 R_1 - I_3 R_3 - I_1 R_4 = 0$$

$$-I_2 R_2 - V_2 - I_2 R_5 + I_3 R_3 = 0$$

Example 28.7

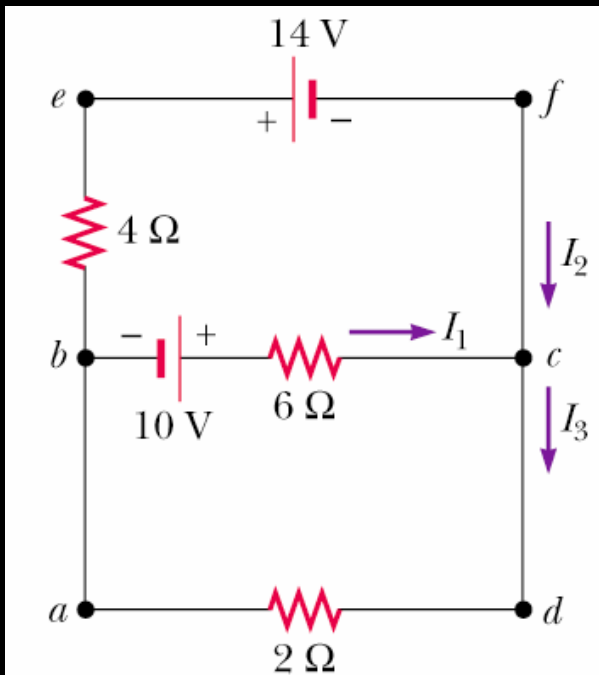

$$I_1 + I_2 = I_3$$

$$10\text{V} - (6\Omega)I_1 - (2\Omega)I_3 = 0 \quad (\text{abcda})$$

$$-(4\Omega)I_2 - 14\text{V} + (6\Omega)I_1 - 10\text{V} = 0 \quad (\text{befcb})$$

$$10\text{V} - (6\Omega)I_1 - (2\Omega)(I_1 + I_2) = 0$$

$$10\text{V} = (8\Omega)I_1 + (2\Omega)I_2$$

$$-24\text{V} = -(6\Omega)I_1 + (4\Omega)I_2$$

$$-12\text{V} = -(3\Omega)I_1 + (2\Omega)I_2$$

$$22\text{V} = (11\Omega)I_1$$

$$I_1 = 2\text{A}$$

$$I_2 = -3\text{A}$$

$$I_3 = -1\text{A}$$

$$V_{BC} = -10\text{V} + (6\Omega)I_1$$

$$V_{BC} = -10\text{V} + 12\text{V} = 2\text{V}$$

RC Circuits

- Circuit includes a resistor, a capacitor, possibly a battery and a switch.
- When the battery is connected, the current charges the capacitor through the resistor.
- Without the battery, the accumulated charge on the capacitor is discharged through the resistor.
- Either way, a time-varying, temporary current is created.

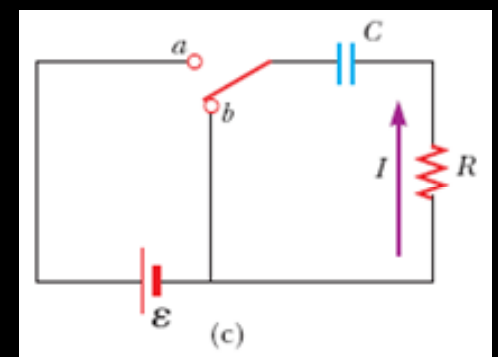
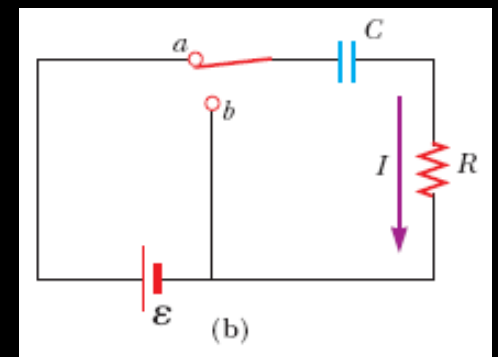
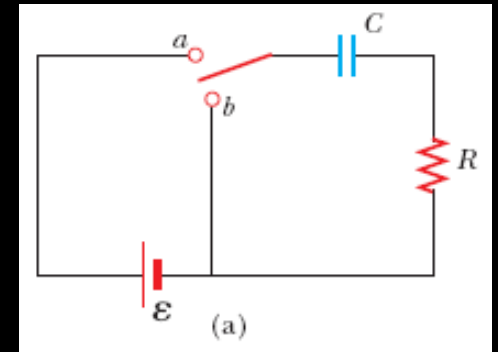

Charging a Capacitor

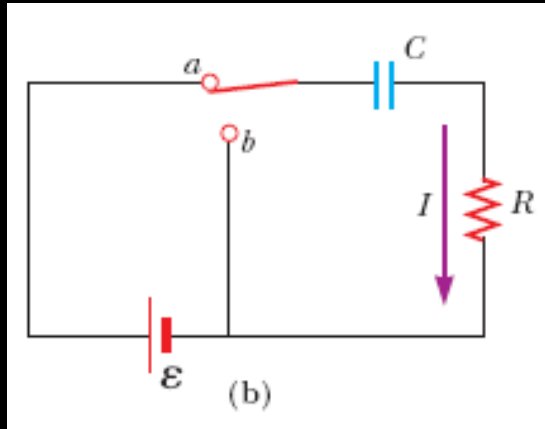

$$\mathcal{E} - \frac{q}{C} - IR = 0$$

$$t = 0$$

$$\mathcal{E} - I_0 R = 0$$

$$I_0 = \frac{\mathcal{E}}{R}$$

$$q = Q$$

$$Q = C\mathcal{E}$$

$$I = \frac{dq}{dt}$$



$$\frac{dq}{dt} = -\frac{q - C\mathcal{E}}{RC}$$

$$\frac{dq}{q - C\mathcal{E}} = -\frac{dt}{RC}$$

$$q(t) = C\mathcal{E}(1 - e^{-t/\tau}) = Q(1 - e^{-t/\tau})$$

$$I(t) = \frac{dq}{dt} = \frac{\mathcal{E}}{R} e^{-t/\tau}$$

$$\tau = RC$$

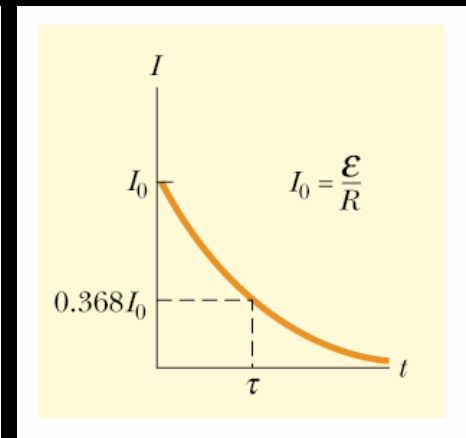
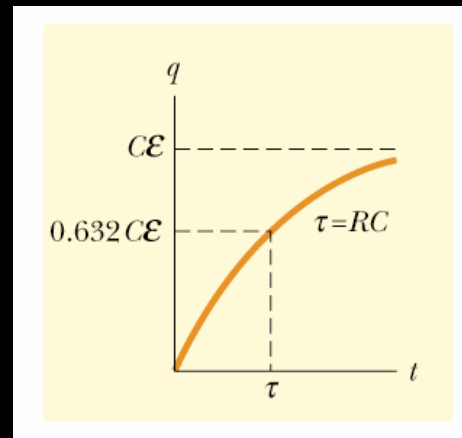

Discharging a Capacitor

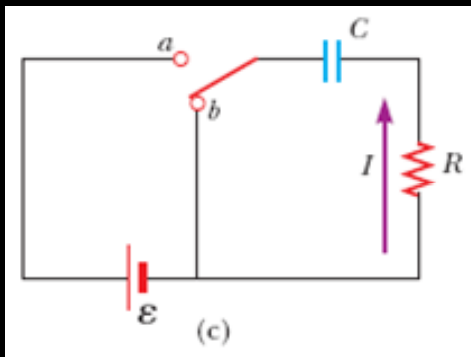

$$-\frac{q}{C} - IR = 0$$

$$t = 0 \quad q = Q, I = 0$$

$$I = \frac{dq}{dt}$$

$$-R \frac{dq}{dt} = \frac{q}{C}$$

$$q(t) = Qe^{-t/\tau}$$

$$I(t) = \frac{dq}{dt} = -\frac{Q}{RC} e^{-t/\tau}$$

$$\tau = RC$$

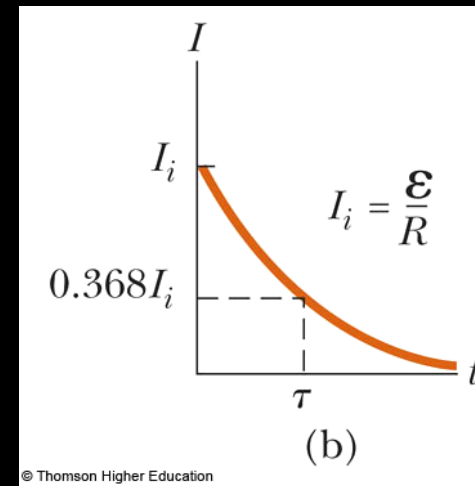

Charge/Discharge Example

- See Active Figure 28.16
(http://www.webassign.net/serpse/AF/AF_2816.swf)

$\mathcal{E} = 10 \text{ V}$, $R = 1 \text{ M}\Omega$ and $C = 1.5 \text{ }\mu\text{F}$

- Find I_0 , Q , τ
- How long to discharge half the maximum charge?
- Maximum energy stored?
- How long to release half of the stored energy?

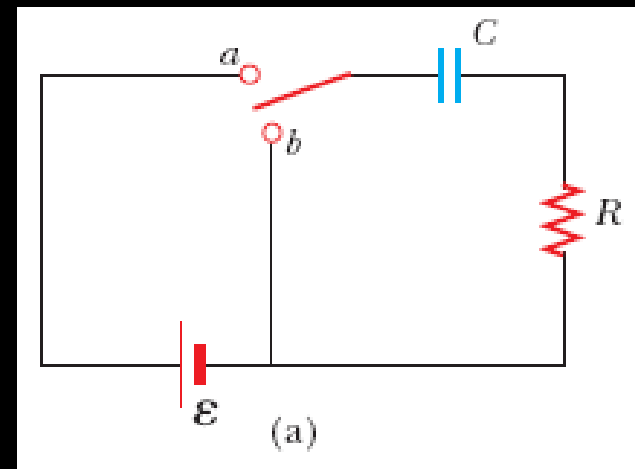

Ammeters and Voltmeters

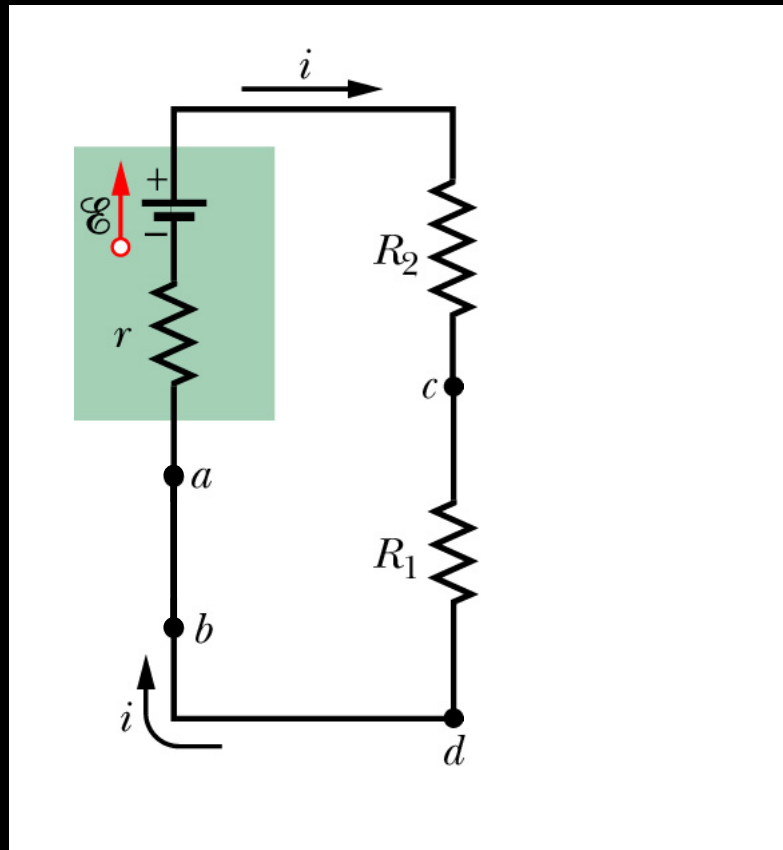

An ideal ammeter should have no resistance. In practice, its resistance should be very low compared to the circuit it is attached to.

An ideal voltmeter should have infinite resistance. In practice, its resistance should be very high compared to the element it is attached to.

Summary

- EMF device as a charge pump
- Power and energy in circuits
- Loop and junction rules
- Resistors in series and parallel
- RC Circuits

For Next Class

- Midterm 1 Review on Wednesday
- Midterm 1 on Thursday
- Reading Assignment for Friday
 - Chapter 29 – Magnetic Fields
- WebAssign: Assignment 6 (due Wednesday, 11 PM)