

Electrodynamics – PHY712

Lecture 5 – Introduction to numerical methods for solving Poisson and Laplace equations

Reference: Chap. 1 & 2 in J. D. Jackson's textbook.

1. Finite difference methods with 2-dimensional example (Section 1.13 of your textbook)
2. Finite element methods with 2-dimensional example (Section 2.12 of your textbook)

Future topics

1. Method of images for planar and spherical geometries
2. Special functions associated with the electrostatic potential in various geometries

Numerical methods to solve Poisson and Laplace equations; Finite difference methods

The basis for grid-based finite difference methods is a Taylor's series expansion:

$$\Phi(\mathbf{r} + \mathbf{u}) = \Phi(\mathbf{r}) + \mathbf{u} \cdot \nabla \Phi(\mathbf{r}) + \frac{1}{2!} (\mathbf{u} \cdot \nabla)^2 \Phi(\mathbf{r}) + \frac{1}{3!} (\mathbf{u} \cdot \nabla)^3 \Phi(\mathbf{r}) + \frac{1}{4!} (\mathbf{u} \cdot \nabla)^4 \Phi(\mathbf{r}) + \dots \quad (1)$$

For the 2-dimensional Poisson equation we have

$$\left(\frac{\partial^2}{\partial x^2} + \frac{\partial^2}{\partial y^2} \right) \Phi(x, y) = -\frac{\rho(x, y)}{\epsilon_0}. \quad (2)$$

Examples of 2-dimensional regular grids on a square with h denoting the spacing between grid points

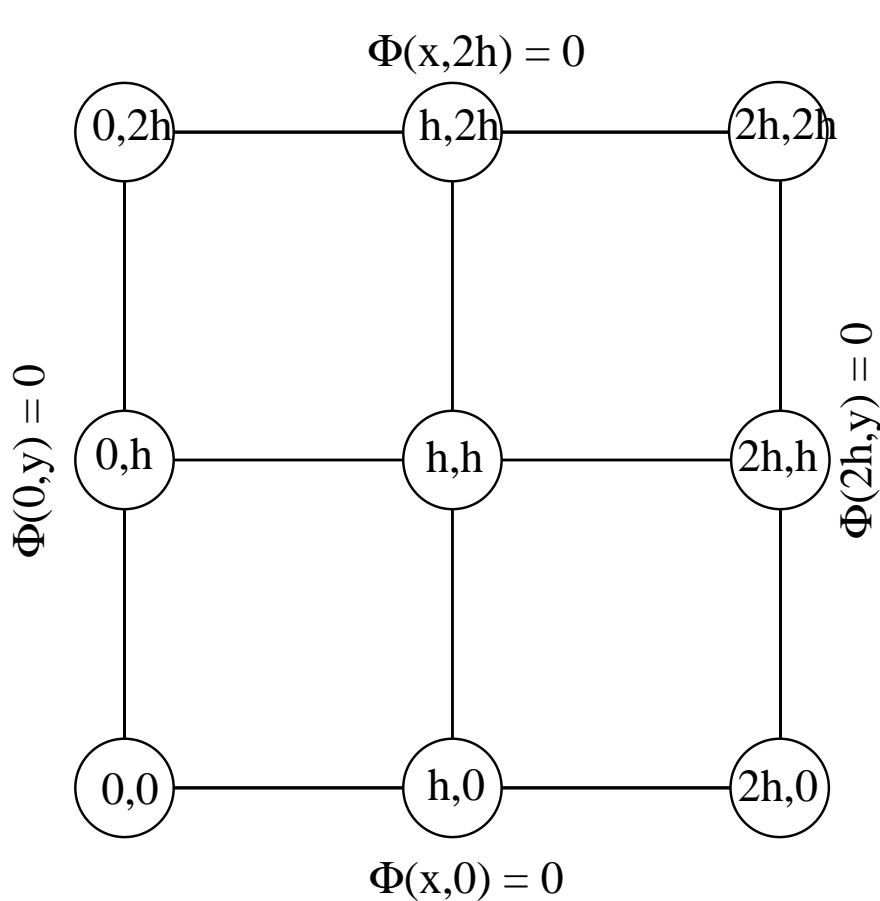

3×3 grid for solution of the Poisson equation within a 2-dimensional square.

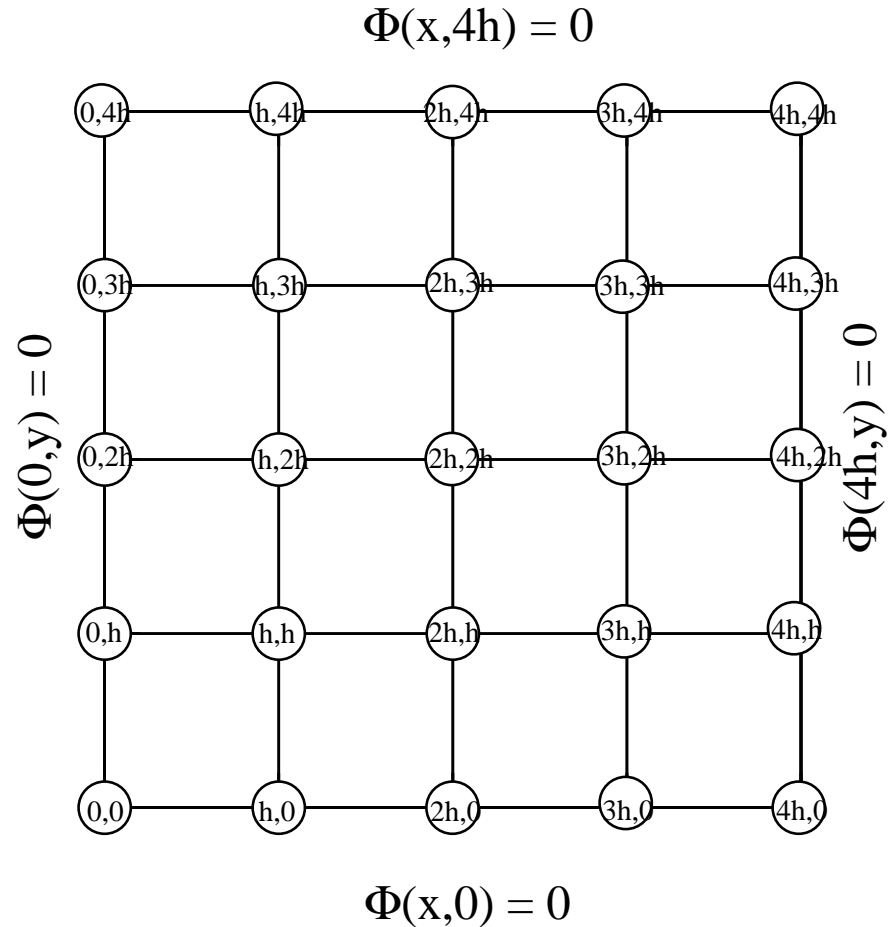

5×5 grid for solution of the Poisson equation within a 2-dimensional square.

Finite difference example for a 2-dimensional square

We will work out some explicit formulae for a 2-dimensional regular grid with h denoting the step length. We note that a sum of 4 surrounding edge values gives:

$$\begin{aligned} S_A &\equiv \Phi(x+h, y) + \Phi(x-h, y) + \Phi(x, y+h) + \Phi(x, y-h) \\ &= 4\Phi(x, y) + h^2 \left(\frac{\partial^2}{\partial x^2} + \frac{\partial^2}{\partial y^2} \right) \Phi(x, y) + \frac{h^4}{12} \left(\frac{\partial^4}{\partial x^4} + \frac{\partial^4}{\partial y^4} \right) \Phi(x, y) + (h^6 \dots). \end{aligned} \quad (3)$$

Similarly, a sum of 4 surrounding corner values gives:

$$\begin{aligned} S_B &\equiv \Phi(x+h, y+h) + \Phi(x-h, y+h) + \Phi(x+h, y-h) + \Phi(x-h, y-h) \\ &= 4\Phi(x, y) + 2h^2 \left(\frac{\partial^2}{\partial x^2} + \frac{\partial^2}{\partial y^2} \right) \Phi(x, y) + \frac{h^4}{6} \left(\frac{\partial^4}{\partial x^4} + \frac{\partial^4}{\partial y^4} + 6 \frac{\partial^2}{\partial x^2} \frac{\partial^2}{\partial y^2} \right) \Phi(x, y) + (h^6 \dots). \end{aligned} \quad (4)$$

We note that we can combine these two results into the relation

$$S_A + \frac{1}{4}S_B = 5\Phi(x, y) + \frac{3h^2}{2} \nabla^2 \Phi(x, y) + \frac{h^4}{8} \nabla^2 \nabla^2 \Phi(x, y) + (h^6 \dots). \quad (5)$$

This result can be written in the form;

$$\Phi(x, y) - \frac{1}{5}S_A - \frac{1}{20}S_B = \frac{3h^2}{10\epsilon_0} \rho(x, y) + \frac{h^4}{40\epsilon_0} \nabla^2 \rho(x, y). \quad (6)$$

Finite difference example for a 2-dimensional square – continued

Equation derived above:

$$\Phi(x, y) - \frac{1}{5}S_A - \frac{1}{20}S_B = \frac{3h^2}{10\epsilon_0}\rho(x, y) + \frac{h^4}{40\epsilon_0}\nabla^2\rho(x, y). \quad (7)$$

In general, the right hand side of this equation is known, and most of the left hand side of the equation, except for the boundary values are unknown. It can be used to develop a set of linear equations for the values of $\Phi(x, y)$ on the grid points.

For example, consider a solution to the Poisson equation in the square region $0 \leq x \leq a$, $0 \leq y \leq a$ with boundary values $\Phi(x, 0) = \Phi(0, y) = \Phi(a, y) = 0$ and $\Phi(x, a) = 0$ and with the charge distribution

$$\rho(x, y) = \rho_0 \sin\left(\frac{\pi x}{a}\right) \sin\left(\frac{\pi y}{a}\right) \quad \text{for } 0 \leq x \leq a \quad \text{and} \quad 0 \leq y \leq a. \quad (8)$$

It can be shown that the exact potential for this case is given by

$$\Phi(x, y) = \frac{\rho_0 a^2}{\epsilon_0} \frac{1}{2\pi^2} \sin\left(\frac{\pi x}{a}\right) \sin\left(\frac{\pi y}{a}\right). \quad (9)$$

Finite difference example for a 2-dimensional square – continued

We will first analyze this system with a mesh of 9 points generated with a grid spacing of $h = \frac{a}{2}$. In this case, $\Phi(h, h) \equiv \Phi(\frac{a}{2}, \frac{a}{2})$ is unknown, while the 8 boundary points are zero: $\Phi(0, 2h)$, $\Phi(h, 2h)$, $\Phi(2h, 2h)$, $\Phi(0, 0)$, $\Phi(h, 0)$, $\Phi(2h, 0)$, $\Phi(0, h)$, $\Phi(h, 2h)$.

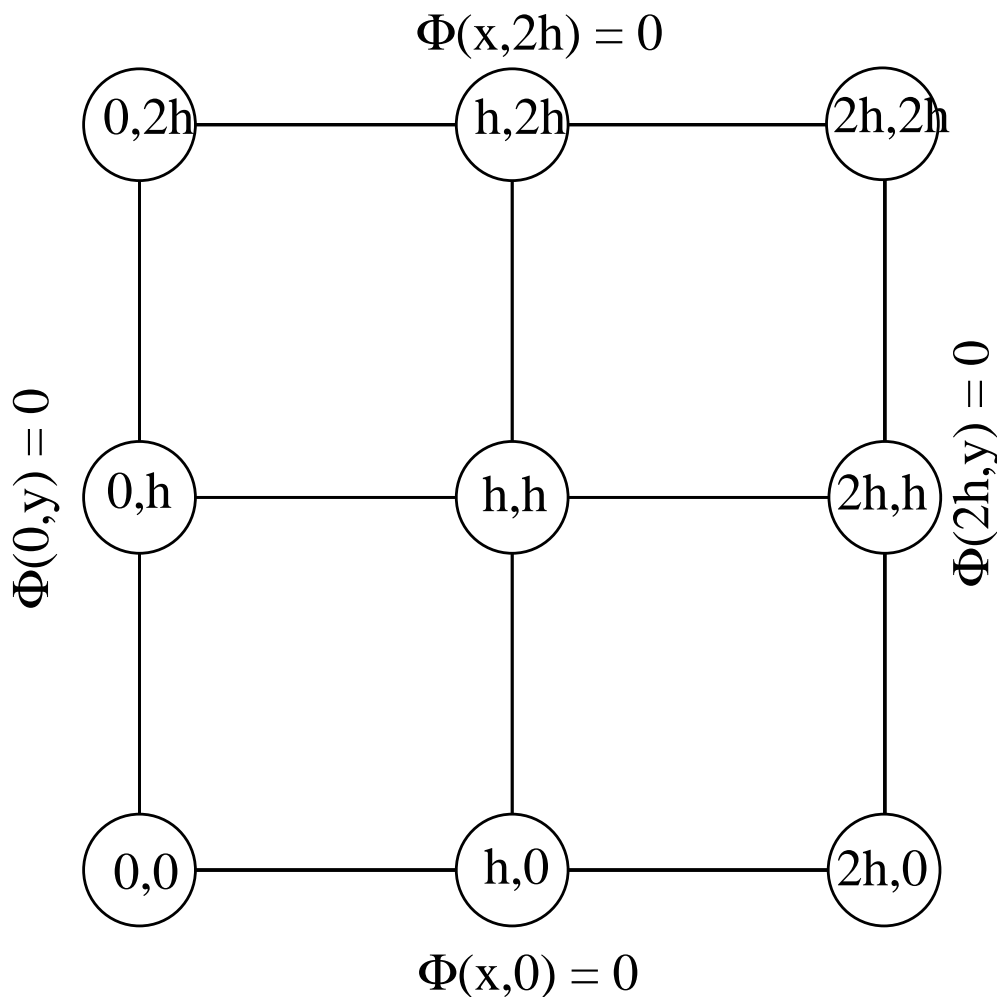

3×3 grid for solution of the Poisson equation within a 2-dimensional square.

Finite difference example for a 2-dimensional square – continued

For this example, Eq. 7 states

$$\Phi(h, h) = \frac{3h^2}{10\epsilon_0} \rho(h, h) + \frac{h^4}{40\epsilon_0} \nabla^2 \rho(h, h). \quad (10)$$

Evaluating this result for our example, we find

$$\Phi(h, h) \equiv \Phi\left(\frac{a}{2}, \frac{a}{2}\right) = \frac{\rho_0 a^2}{\epsilon_0} \left(\frac{2}{40} - \frac{\pi^2}{320} \right). \quad (11)$$

In this case, the constant in the parenthesis is 0.044 compared with 0.051 for the exact results.

Finite difference example for a 2-dimensional square – continued

If analyze this same system with the next more accurate grid, $h = \frac{a}{4}$, using the symmetry of the system $\Phi(x, y) = \Phi(a - x, y)$, we have now 6 unknown values $\{\Phi(h, h), \Phi(2h, h), \Phi(h, 2h), \Phi(2h, 2h), \Phi(h, 3h), \Phi(2h, 3h)\}$.

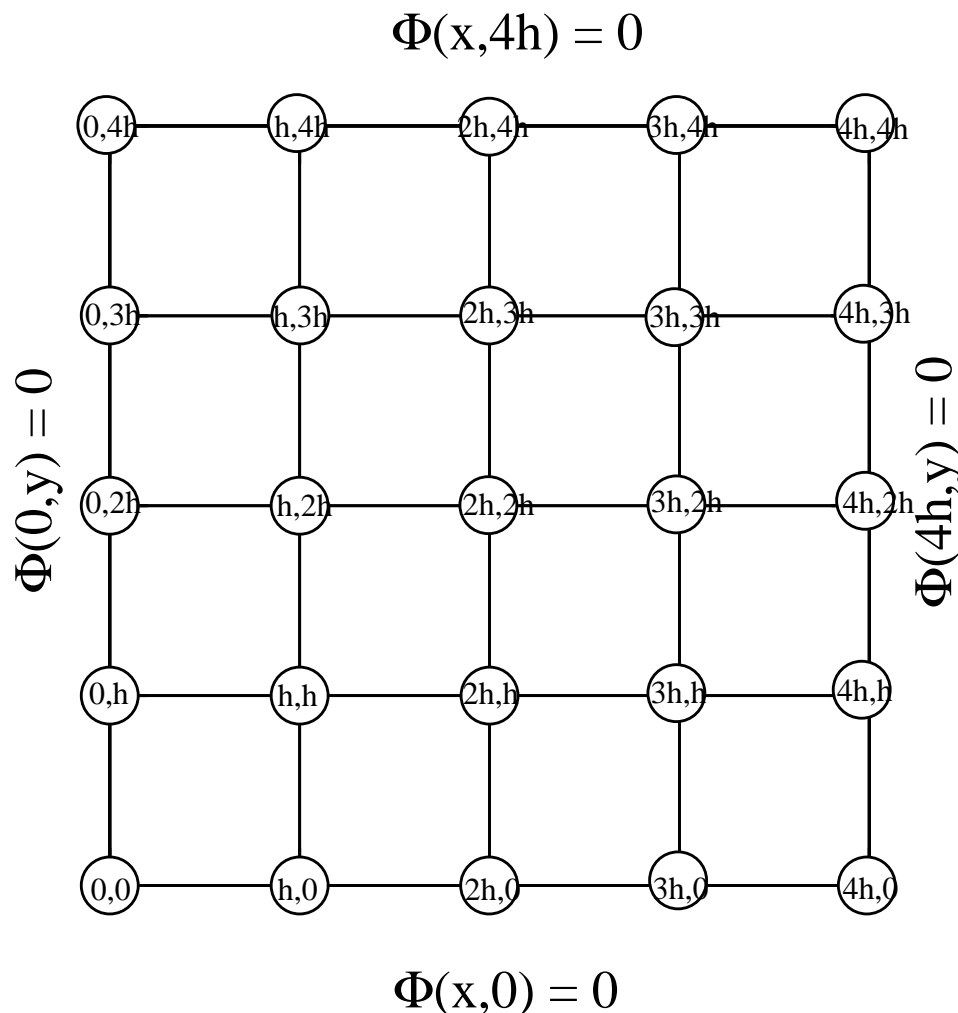

5×5 grid for solution of the Poisson equation within a 2-dimensional square.

Finite difference example for a 2-dimensional square – continued

This results in the following relations between the grid points:

$$\begin{aligned} \Phi(h, 3h) - \frac{1}{5}(\Phi(h, 4h) + \Phi(0, 3h) + \Phi(2h, 3h) + \Phi(h, 2h)) \\ - \frac{1}{20}(\Phi(0, 4h) + \Phi(2h, 4h) + \Phi(2h, 2h) + \Phi(0, 2h)) = \frac{3h^2}{10\epsilon_0}\rho(h, 3h) + \frac{h^4}{40\epsilon_0}\nabla^2\rho(h, 3h). \end{aligned} \quad (12)$$

$$\begin{aligned} \Phi(2h, 3h) - \frac{1}{5}(\Phi(2h, 4h) + \Phi(3h, 3h) + \Phi(h, 3h) + \Phi(2h, 2h)) \\ - \frac{1}{20}(\Phi(h, 4h) + \Phi(3h, 4h) + \Phi(3h, 2h) + \Phi(h, 2h)) = \frac{3h^2}{10\epsilon_0}\rho(2h, 3h) + \frac{h^4}{40\epsilon_0}\nabla^2\rho(2h, 3h). \end{aligned} \quad (13)$$

$$\begin{aligned} \Phi(h, 2h) - \frac{1}{5}(\Phi(h, 3h) + \Phi(0, 2h) + \Phi(2h, 2h) + \Phi(h, h)) \\ - \frac{1}{20}(\Phi(0, 3h) + \Phi(2h, 3h) + \Phi(0, h) + \Phi(2h, h)) = \frac{3h^2}{10\epsilon_0}\rho(h, 2h) + \frac{h^4}{40\epsilon_0}\nabla^2\rho(h, 2h). \end{aligned} \quad (14)$$

$$\begin{aligned} \Phi(2h, 2h) - \frac{1}{5}(\Phi(2h, 3h) + \Phi(h, 2h) + \Phi(3h, 2h) + \Phi(2h, h)) \\ - \frac{1}{20}(\Phi(3h, 3h) + \Phi(h, 3h) + \Phi(3h, h) + \Phi(h, h)) = \frac{3h^2}{10\epsilon_0}\rho(2h, 2h) + \frac{h^4}{40\epsilon_0}\nabla^2\rho(2h, 2h). \end{aligned} \quad (15)$$

Finite difference example for a 2-dimensional square – continued

$$\begin{aligned} \Phi(h, h) - \frac{1}{5}(\Phi(h, 2h) + \Phi(0, h) + \Phi(2h, h) + \Phi(h, 0)) \\ - \frac{1}{20}(\Phi(0, 2h) + \Phi(2h, 2h) + \Phi(0, 0) + \Phi(2h, 0)) = \frac{3h^2}{10\epsilon_0}\rho(h, h) + \frac{h^4}{40\epsilon_0}\nabla^2\rho(h, h). \end{aligned} \quad (16)$$

$$\begin{aligned} \Phi(2h, h) - \frac{1}{5}(\Phi(2h, 2h) + \Phi(3h, h) + \Phi(h, h) + \Phi(2h, 0)) \\ - \frac{1}{20}(\Phi(h, 2h) + \Phi(3h, 2h) + \Phi(h, 0) + \Phi(3h, 0)) = \frac{3h^2}{10\epsilon_0}\rho(2h, h) + \frac{h^4}{40\epsilon_0}\nabla^2\rho(2h, h). \end{aligned} \quad (17)$$

Finite difference example for a 2-dimensional square – continued

These equations can be cast into the form of a matrix problem which can be easily solved using Maple:

$$\begin{pmatrix} 1 & -1/5 & -1/5 & -1/20 & 0 & 0 \\ -2/5 & 1 & -1/10 & -1/5 & 0 & 0 \\ -1/5 & -1/20 & 1 & -1/5 & -1/5 & -1/20 \\ -1/10 & -1/5 & -2/5 & 1 & -1/10 & -1/5 \\ 0 & 0 & -1/5 & -1/20 & 1 & -1/5 \\ 0 & 0 & -1/10 & -1/5 & -2/5 & 1 \end{pmatrix} \begin{pmatrix} \Phi(h, 3h) \\ \Phi(2h, 3h) \\ \Phi(h, 2h) \\ \Phi(2h, 2h) \\ \Phi(h, h) \\ \Phi(2h, h) \end{pmatrix} = \begin{pmatrix} 0.008893085722 \\ 0.01257672244 \\ 0.01257672244 \\ 0.01778617144 \\ 0.008893085722 \\ 0.008893085722 \end{pmatrix} \quad (18)$$

Finite difference example for a 2-dimensional square – continued

The solution to these equations and the exact results are found to be:

$$\begin{pmatrix} \Phi(h, 3h) \\ \Phi(2h, 3h) \\ \Phi(h, 2h) \\ \Phi(2h, 2h) \\ \Phi(h, h) \\ \Phi(2h, h) \end{pmatrix} = \begin{pmatrix} 0.026600951 \\ 0.037619426 \\ 0.037619426 \\ 0.053201903 \\ 0.026600951 \\ 0.037619426 \end{pmatrix} \frac{\rho_0 a^2}{\epsilon_0}; \quad (\text{exact}) = \begin{pmatrix} 0.025330296 \\ 0.035822448 \\ 0.035822448 \\ 0.050660592 \\ 0.025330296 \\ 0.035822448 \end{pmatrix} \frac{\rho_0 a^2}{\epsilon_0}. \quad (19)$$

We see that the results obtained with a smaller mesh has is much closer to the exact results than those for the larger mesh.

Introduction to Finite element method

The finite element approach is based on an expansion of the unknown electrostatic potential in terms of known grid-based functions of fixed shape. In two dimensions, using the indices $\{i, j\}$ to reference the grid, we can denote the shape functions as $\{\phi_{ij}(x, y)\}$. The finite element expansion of the potential in two dimensions can take the form:

$$\Phi(x, y) = \sum_{ij} \psi_{ij} \phi_{ij}(x, y), \quad (20)$$

where ψ_{ij} represents the amplitude associated with the shape function $\phi_{ij}(x, y)$. The amplitude values can be determined for a given solution of the Poisson equation:

$$-\nabla^2 (\Phi(x, y)) = \frac{\rho(x, y)}{\epsilon_0}, \quad (21)$$

by solving a linear algebra problem of the form

$$\sum_{ij} M_{kl,ij} \psi_{ij} = G_{kl}, \quad (22)$$

where

$$M_{kl,ij} \equiv \int dx \int dy \nabla \phi_{kl}(x, y) \cdot \nabla \phi_{ij}(x, y) \quad \text{and} \quad G_{kl} \equiv \int dx \int dy \phi_{kl}(x, y) 4\pi \rho(x, y). \quad (23)$$

Introduction to Finite element method – continued

In obtaining this result, we have assumed that the boundary values vanish. This will be ensured by our choice of the functional form of the shape functions $\phi_{ij}(x, y)$. In order for this result to be useful, we need to be able evaluate the integrals for $M_{kl,ij}$ and for G_{kl} . In the latter case, we need to know the form of the charge density. The form of $M_{kl,ij}$ only depends upon the form of the shape functions. If we take these functions to be:

$$\phi_{ij}(x, y) \equiv \mathcal{X}_i(x)\mathcal{Y}_j(y), \quad (24)$$

where

$$\mathcal{X}_i(x) \equiv \begin{cases} \left(1 - \frac{|x-x_i|}{h}\right) & \text{for } x_i - h \leq x \leq x_i + h \\ 0 & \text{otherwise} \end{cases}, \quad (25)$$

and $\mathcal{Y}_j(y)$ has a similar expression in the variable y .

Introduction to Finite element method – continued

Finite element basis functions in this case

$$\mathcal{X}_i(x) \equiv \begin{cases} \left(1 - \frac{|x-x_i|}{h}\right) & \text{for } x_i - h \leq x \leq x_i + h \\ 0 & \text{otherwise} \end{cases}, \quad (26)$$

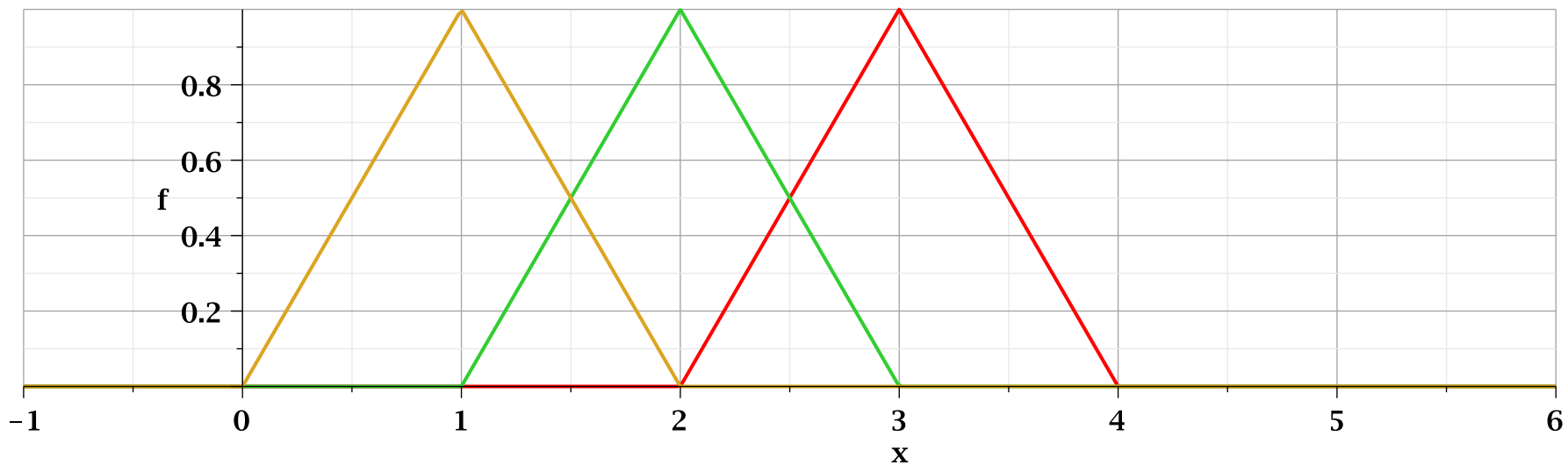

Introduction to Finite element method – continued

The matrix function takes the form:

$$M_{kl,ij} \equiv \int dx \int dy \left[\frac{d\mathcal{X}_k(x)}{dx} \frac{d\mathcal{X}_i(x)}{dx} \mathcal{Y}_l(y) \mathcal{Y}_j(y) + \mathcal{X}_k(x) \mathcal{X}_i(x) \frac{d\mathcal{Y}_l(y)}{dy} \frac{d\mathcal{Y}_j(y)}{dy} \right]. \quad (27)$$

There are four types of non-trivial contributions to these values:

$$\int_{x_i-h}^{x_i+h} (\mathcal{X}_i(x))^2 dx = h \int_{-1}^1 (1 - |u|)^2 du = \frac{2h}{3}, \quad (28)$$

$$\int_{x_i-h}^{x_i+h} (\mathcal{X}_i(x) \mathcal{X}_{i+1}(x)) dx = h \int_0^1 (1 - u)u du = \frac{h}{6}, \quad (29)$$

$$\int_{x_i-h}^{x_i+h} \left(\frac{d\mathcal{X}_i(x)}{dx} \right)^2 dx = \frac{1}{h} \int_{-1}^1 du = \frac{2}{h}, \quad (30)$$

and

$$\int_{x_i-h}^{x_i+h} \left(\frac{d\mathcal{X}_i(x)}{dx} \frac{d\mathcal{X}_{i+1}(x)}{dx} \right) dx = -\frac{1}{h} \int_0^1 du = \frac{-1}{h}. \quad (31)$$

Introduction to Finite element method – continued

The basic equations lead to the following distinct values for the matrix:

$$M_{kl,ij} = \begin{cases} \frac{8}{3} & \text{for } k = i \text{ and } l = j \\ -\frac{1}{3} & \text{for } k - i = \pm 1 \text{ and/or } l - j = \pm 1 \\ 0 & \text{otherwise} \end{cases} . \quad (32)$$

For problems in which the boundary values are 0, Eq. 22 then can be used to find all of the interior amplitudes ψ_{ij} .

Introduction to Finite element method – continued

For the same example we studied before using the 5×5 grid, the finite element approach for this problem thus can be put into the matrix form for analysis by Maple:

$$\begin{pmatrix} 8/3 & -1/3 & -1/3 & -1/3 & 0 & 0 \\ -2/3 & 8/3 & -2/3 & -1/3 & 0 & 0 \\ -1/3 & -1/3 & 8/3 & -1/3 & -1/3 & -1/3 \\ -2/3 & -1/3 & -2/3 & 8/3 & -2/3 & -1/3 \\ 0 & 0 & -1/3 & -1/3 & 8/3 & -1/3 \\ 0 & 0 & -2/3 & -1/3 & -2/3 & 8/3 \end{pmatrix} \begin{pmatrix} \Phi(h, 3h) \\ \Phi(2h, 3h) \\ \Phi(h, 2h) \\ \Phi(2h, 2h) \\ \Phi(h, h) \\ \Phi(2h, h) \end{pmatrix} = \begin{pmatrix} 0.028181825 \\ 0.039855120 \\ 0.039855120 \\ 0.056363651 \\ 0.056363651 \\ 0.039855120 \end{pmatrix} \frac{\rho_0 a^2}{\epsilon_0}. \tag{33}$$

Introduction to Finite element method – continued

The solution to these equations and the exact results are found to be:

$$\begin{pmatrix} \Phi(h, 3h) \\ \Phi(2h, 3h) \\ \Phi(h, 2h) \\ \Phi(2h, 2h) \\ \Phi(h, h) \\ \Phi(2h, h) \end{pmatrix} = \begin{pmatrix} 0.0266572706 \\ 0.0376990736 \\ 0.0376990736 \\ 0.0533145412 \\ 0.0266572706 \\ 0.0376990736 \end{pmatrix} \frac{\rho_0 a^2}{\epsilon_0}; \quad (\text{exact}) == \begin{pmatrix} 0.025330296 \\ 0.035822448 \\ 0.035822448 \\ 0.050660592 \\ 0.025330296 \\ 0.035822448 \end{pmatrix} \frac{\rho_0 a^2}{\epsilon_0}. \quad (34)$$

We see that the results are similar to those obtained using the finite difference approach.